

No. MP006-A-P-SD-2.1

TITLE	SOT236-A-PKG Dimensions
No.	MP006-A-P-SD-2.1
ANGLE	
UNIT	mm
ABLIC Inc.	

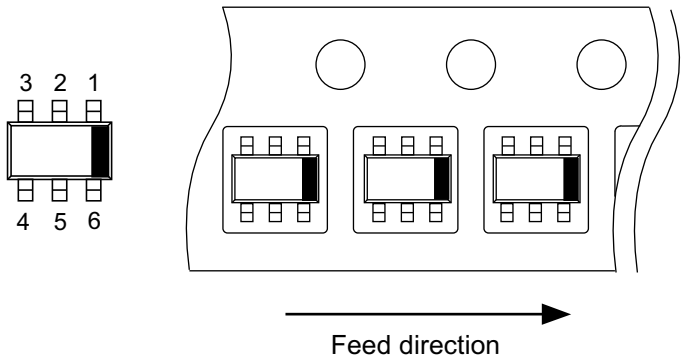
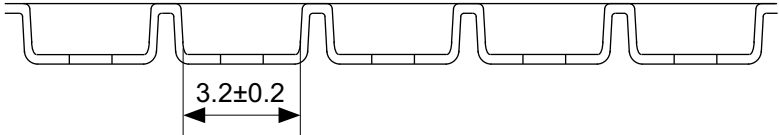
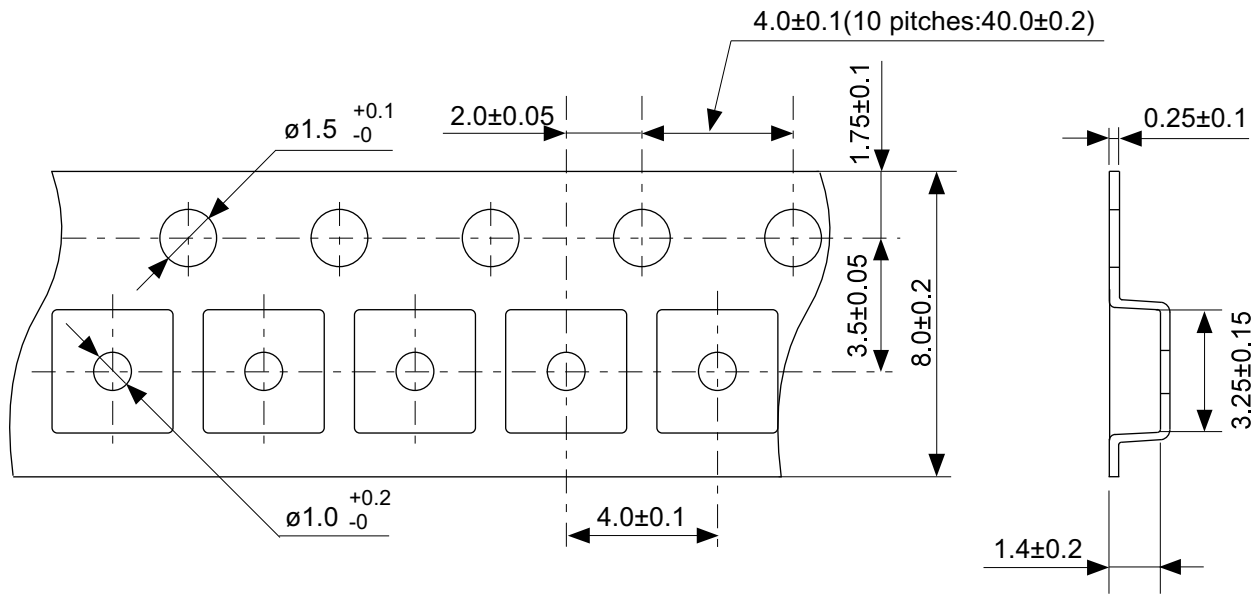

No. MP006-A-C-SD-3.1

TITLE	SOT236-A-Carrier Tape
No.	MP006-A-C-SD-3.1
ANGLE	
UNIT	mm
ABLIC Inc.	

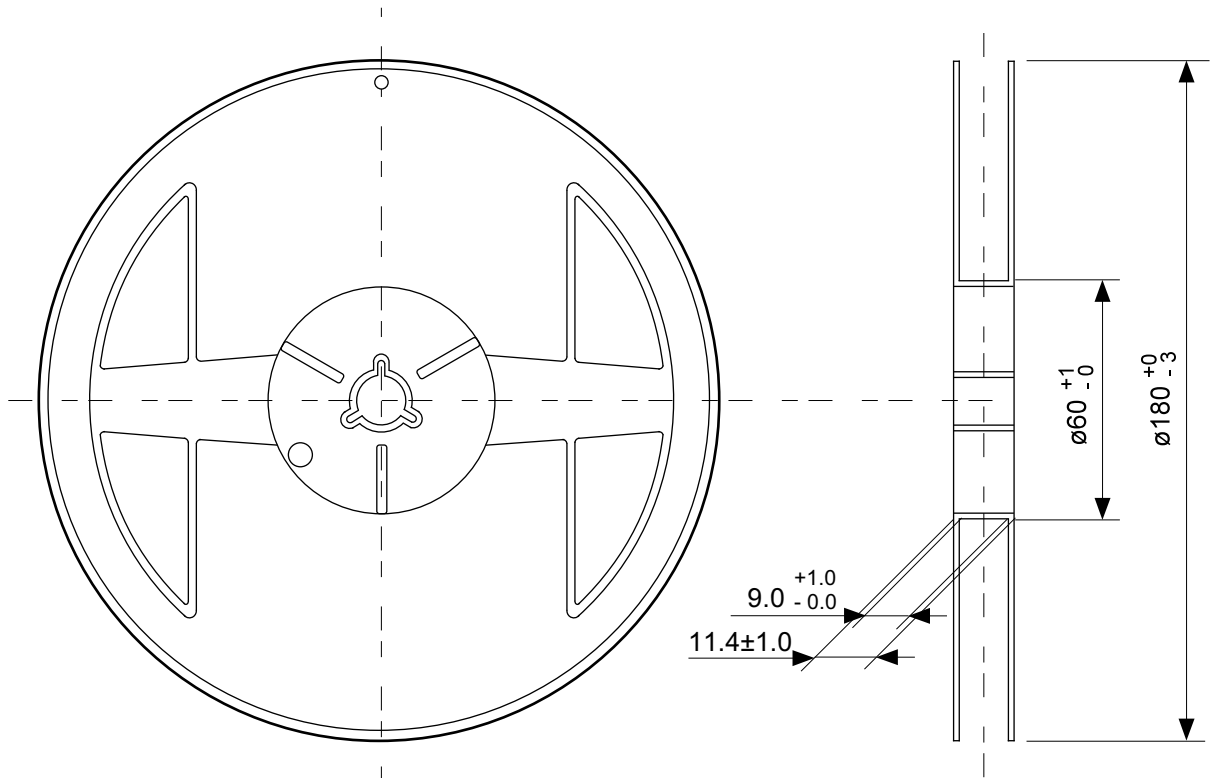

Enlarged drawing in the central part

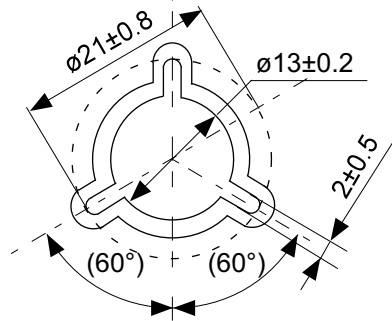

No. MP006-A-R-SD-3.0

TITLE	SOT236-A-Reel		
No.	MP006-A-R-SD-3.0		
ANGLE		QTY	3,000
UNIT	mm		
ABLIC Inc.			

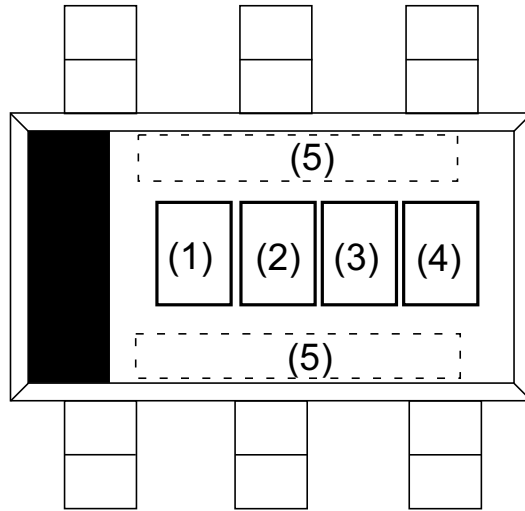

(1) to (3) : Product code

(4) : Month of assembly

(5) : Dot on one side (Year and week of assembly)

No. MP006-A-M-SD-1.1

TITLE	SOT236-A-Markings		
No.	MP006-A-M-SD-1.1		
ANGLE			
UNIT		TYPE	LASER
ABLIC Inc.			

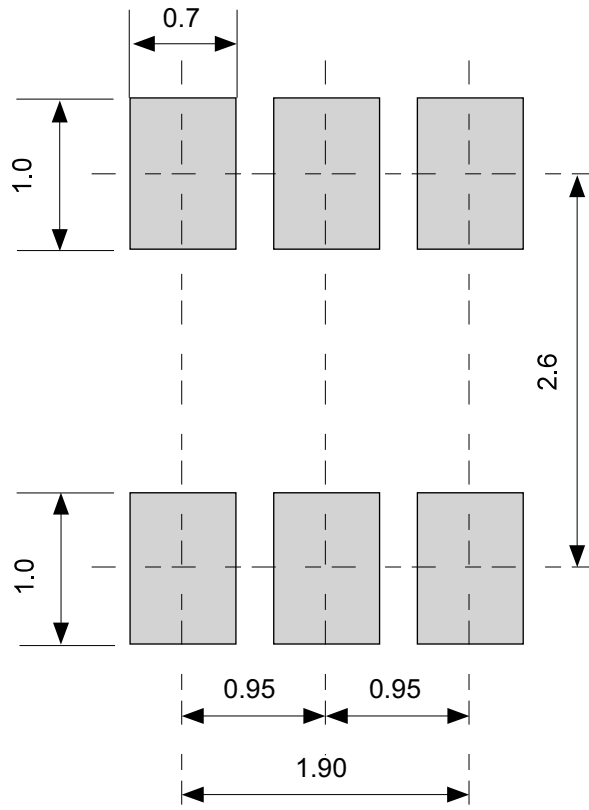

No. MP006-A-L-SD-1.1

TITLE	SOT236-A -Land Recommendation
No.	MP006-A-L-SD-1.1
ANGLE	
UNIT	mm
ABLIC Inc.	